

Two Channels Digital Output LVDT Signal Conditioner with calibration capability. DOLSC-2-B



DOLSC-2-B is a 2 channels digital output conditioner for LVDT sensors.

Features :

- .Power supply 5 Volts DC
- .0-5 V RS232 type asynchronous digital input-output
- .Built in calibration process.
- .Non-volatile memory to store calibration parameters
- .Easy to use.

Specifications :

- Power supply.....5 Volts DC +/- 10 %
- Current supply.....50 mA Max
- LVDT excitation10 Volts peak to peak 20 mA Max/channel.
- Frequency excitation5 KHz
- Voltage input range.....+/- 2.5 Volts peak Max (1:1 Sensors)
- Accuracy.....2 000 points
- Sampling rate10 /second.
- Baud rate : 9 600 bauds, 1 start, 8 data, 1 stop, no parity
- Operating temperature range...0 to 50 °C
- Dimensions.....42.5x52mm H=10mm
- J1 5 way HE14 power supply connector.
- J2 6 way HE14 serial I/O connector.
- J3 10 way connector to sensors : Molex Picoflex 90-325-0010 connected to 90327-0310 for 28AWG 1,27 10pts flat cable L=90 mm supplied.

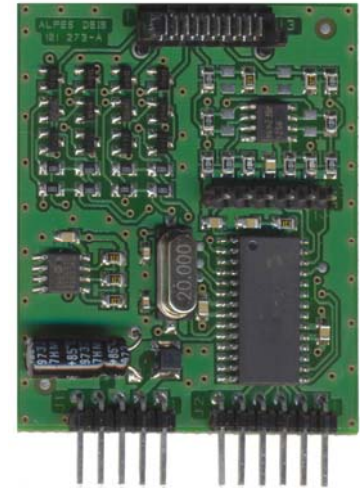

After power on, DOLSC-2-B outputs on TxD line serial number and embedded software version and during 5 seconds, waits a calibration command "CLY" (y = either A or B) on RxD line. If this command is not received, DOLSC-2-B switches automatically in Running Mode and output data on TxD line, every 100 mS, with calibration parameters precedently stored in non volatile memory . In calibration mode, the user has to enter 2 points of calibration by channel with CA0...CB1 commands. The format used to enter calibration points defines the output format of running mode. The format must be the same for the 2 calibration points. Formats allowed are : from -9999. to +9999. or -999.9 to +999.9 or -99.99 to +99.99 or -9.999 to +9.999 or -.9999 to

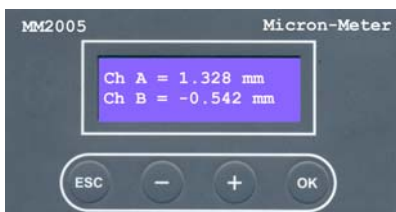

Typical application : front panel meter

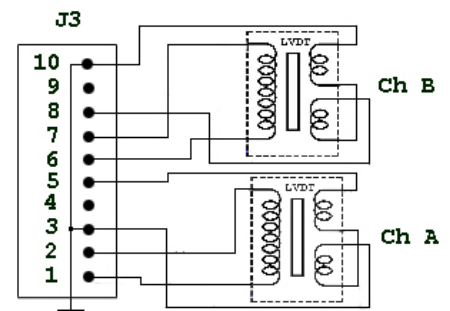
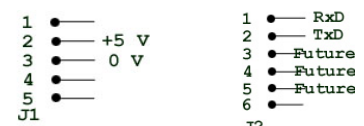
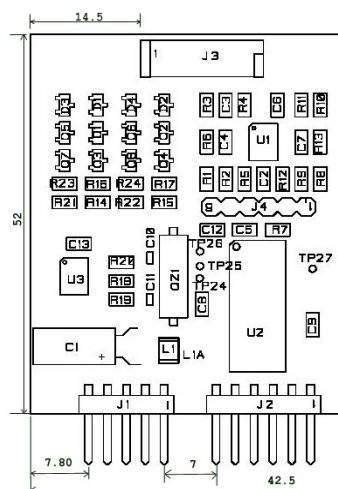

This board is designed to comply with EN 61000-6-2 and EN 61000-6-4 , but integrator has to test his entire device to get the approval. Embedded software is deposit under IDDN number FR.001.070004.000.R.P.2005.000.30640

DOLSC-2-B

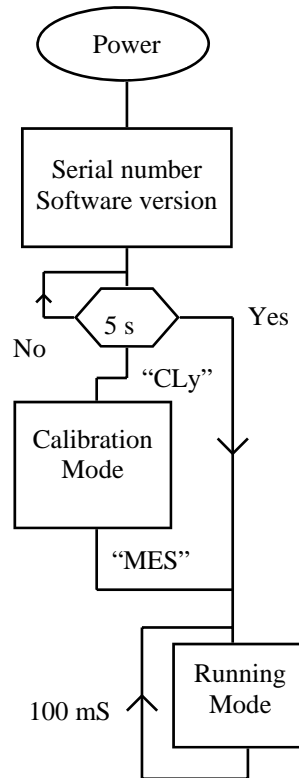

Power-On :

TxD : "N:xxxxx"CR,LF

TxD : "V:x.x"CR,LF

Calibration Mode :

-within 5 seconds after power-on

-RxD : "CLA" CR,LF Calibration mode TxD : "CLA"CR,LF

-RxD : "CLB" CR,LF TxD : "CLB"CR,LF

-RxD : "CA0+x.xxx" CR,LF TxD : "CA0+x.xxx" CR,LF

-RxD : "CA1+x.xxx" CR,LF TxD : "CA1+x.xxx" CR,LF

-RxD : "CB0+x.xxx" CR,LF TxD : "CB0+x.xxx" CR,LF

-RxD : "CB1+x.xxx" CR,LF TxD : "CB1+x.xxx" CR,LF

-RxD : "SCA" CR,LF Save channel A calibration points; If OK

- TxD : "SCA" CR,LF

- Else TxD : "Er1" CR,LF

-RxD : "SCB" CR,LF Save channel B calibration points; If OK

- TxD : "SCB" CR,LF

- Else TxD : "Er1" CR,LF

-RxD : "MES" CR,LF Measurement mode TxD : "MES" CR,LF

Running Mode :

-5 seconds after power-on or after "MES" command from calibration mode :

-TxD : "A:+x.xxx" CR, LF

-TxD : "B:+x.xxx" CR, LF

..... wait

-TxD : "A:+x.xxx" CR, LF

-TxD : "B:+x.xxx" CR, LF

2 channels

every 100 mS